

AN AREA EFFICIENT 16-QAM TRANSCEIVER DESIGN USING VEDIC MULTIPLIER FOR WIRELESS APPLICATIONS

Dhanasekar Subramaniyam^{1*}, P.Malin Bruntha¹, K.Martin Sagayam¹, Lawrence Henesey², Robert Bestak³, Wade Al-Halabi⁴

¹Department of Electronics and Communication Engineering, Karunya Institute of Technology and Sciences, Coimbatore, Tamilnadu, India.

²Faculty of Computer Science and Engineering, Blekinge Institute of Technology, Sweden

³Department of Telecommunication Engineering, Czech Technical University, Prague, Czech Republic.

⁴Director of Visual Reality Center, Effat University, Saudi Arabia

*dhanasekar.sm@gmail.com, malin@karunya.edu, martinsagayam.k@gmail.com, larry.henesey@bth.se, larry.henesey@bth.se, walhalabi@effatuniversity.edu.sa

Abstract

In this research article, an area efficient 16-Quadrature Amplitude Modulation (QAM) transceiver design is introduced using Vedic multiplier. The 16-QAM design is transmitted using Pseudo Random Binary Sequence (PRBS) and modulated by changeable clock frequencies. The Vedic multiplier uses Urdhva Tiryakbhyam (Vertical and Crosswise) method of multiplication to reduce the undesirable steps and generates parallel partial products. Compressor adders are used in the Vedic multipliers, which helps to increase the speed of multiplication process and reduces the carry delay. Four Compressor adders namely 5-3, 10-4, 15-4 and 20-5 are used in a 16-bit Urdhva Tiryakbhyam Vedic multiplier to add its partial products. The proposed 16-QAM is also implemented using Spartan-3 XC3S200-5 pq208 Field Programmable Gate Array (FPGA) device occupies 672 slices, 1102 4-input Look up Tables (LUTs) and 39 mW of power consumption. The Vedic multiplier based 16-QAM transceiver design reduces 17.2% slices and 4.5% 4-input LUTs. The 16-QAM is a preferred digital modulation method in the Orthogonal Frequency Division Multiplexing (OFDM) system, which reduces bit errors and noise effects during data transmission. The OFDM transceiver design used in the high-speed wireless communication by excellence of its Multi-carrier modulation method

Keywords: OFDM, BPSK, QPSK, OPSK, QAM, LUT, FPGA, PRBS, DVB

I. INTRODUCTION

Today, the growth of wideband wireless communication system has been raised due to customer interest towards high-speed wireless communication in which OFDM transceiver design plays vital role. The OFDM system used for high speed data transmission by virtue of its Multi-carrier modulation techniques and intended for high spectral efficiency. The orthogonal subcarriers in an OFDM system offer narrow bandwidth. The different modulation techniques, such as Binary Phase Shift Keying (BPSK), Quadrature Phase Shift Keying (QPSK), Offset Quadrature Phase Shift Keying (OQPSK), QAM etc., are used for transmitting the subcarriers of the OFDM system. For modulation of information signals (towards carrier signal), QAM is one of the extensively used modulation techniques. This is used for radio communications [1]. QAM provides various important vantage points over other modulation techniques, as it carries data on both amplitude and phase. There are various forms of QAMs available namely 16-QAM, 32 QAM, 64 QAM, 128 QAM, and 256 QAM [2].

In this paper, a 16-QAM transceiver design is selected for transmitting digital information toward a band-pass channels to reduce bandwidth and increase the data rate. In 16-QAM modulation method, two carrier signals shifted by 90 degree phase difference are used to modulate data and the resultant output signal has both phase and amplitude variations [3]. The 16-QAM is a preferred digital modulation technique in wireless communication, which reduces noise effects and bit errors during data transmission. The proposed 16-QAM design is transmitted through Pseudo Random Binary Sequence and it is modulated by variable clock frequencies (150 Hz to 19.2 KHz). There are various 16-QAM transceiver design achieves an area efficient architecture in FPGA has been studied [4] –[7].

Urdhva Tiryakbhyam Vedic multiplier used in 16-QAM design provides an area efficient architecture. Urdhva Tiryakbhyam (Vertical and Crosswise) multiplication method used in the Vedic multiplier, which helps to reduce hardware complexity as studied [8]-[12]. The QAM modulated signal is multiplied with sine and cosine carriers using Vedic multiplier. The compressor adders are used to add the parallel partial products and reduce the propagation delay in the multiplier circuit. Vedic multiplier based 16-QAM design occupies less area as compared to existing modulation techniques. The 16-QAM design is used in digital terrestrial television using Digital Video Broadcasting (DVB) and Wireless Fidelity (WIFI) Networking Standards. For accuracy in simulation, testing and implementation of the

proposed designs in the hardware, the FPGA technology can be used which is more flexible and reliable [13]. The Vedic multiplier based 16-QAM transceiver design implemented using Spartan 3FPGA, describes the step by step journey of signal transmission from source to destination with serial bit patterns.

This paper methodized the Quadrature Amplitude Modulation in Section II. Section III discusses an Urdhva Tiryakbhyam based Vedic multiplier using compressor adders. Section IV portrays a proposed 16-QAM design using Vedic multiplier. The results of 16-QAM transceiver design are discussed in Section V. Finally, a conclusion is presented in Section VI.

II. QUADRATURE AMPLITUDE MODULATION

The Quadrature Amplitude Modulation is widely used in many digital communication applications. In 16-QAM modulation technique, the two sinusoidal carrier signals are modulated independently by 90 degree phase shift and demodulated separately at the receiver. A 16-QAM is the band pass digital modulation, which modulates both the amplitude and phase of the carrier signal and provides better error performance in the receiver. The two carrier signals in-phase(I) and quadrature phase (Q) in 16-QAM design are represented as:

$$I(t) = a_i \cos (2\pi f_c t) \quad (1)$$

$$Q(t) = b_i \sin (2\pi f_c t) \quad (2)$$

where I (t) and Q (t) are modulating signals and f_c represents the carrier frequency.

In 16-QAM, a total of 16 possible states (symbols) and each symbol consist of four bits (i.e.) two bits for I and two bits for Q components. There are 16 symbols in the QAM design and each symbol has two gray coded bits of I and Q .A Constellation diagram is used to plot those symbols in rectangular space. The 16-QAM design has 4 amplitudes and 12 phases. The discrete amplitudes used for 16-QAM design are ± 3 and ± 1 . A Constellation diagram of the 16-QAM design is shown in Figure 1. In symbol mapper, transition will occur from any state to other state at each symbol time [4].

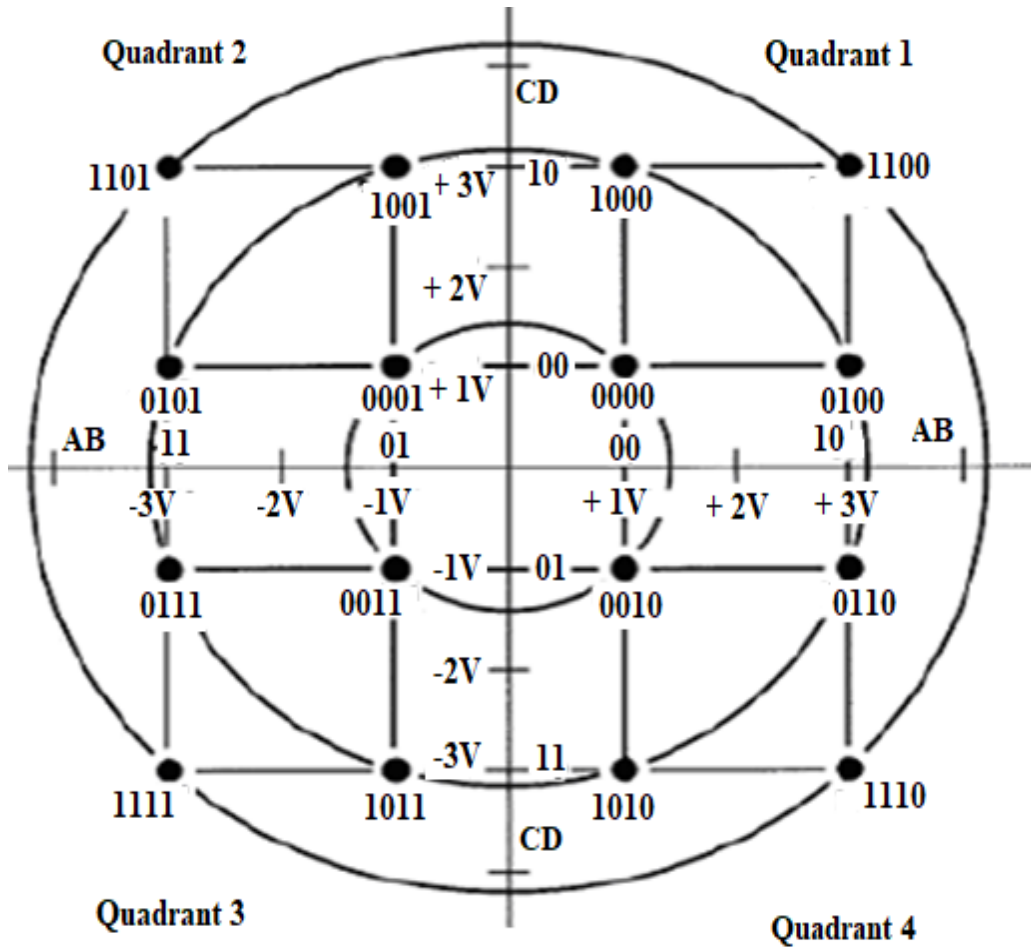

Figure 1 Constellation diagram of 16-QAM

The general form of a 16 QAM signal [14] is expressed as

$$T_x(t) = \sqrt{\frac{2E_{\min}}{T_s}} a_i \cos 2\pi f_c t + \sqrt{\frac{2E_{\min}}{T_s}} b_i \sin 2\pi f_c t \quad (3)$$

$$0 \leq t \leq T_s; i = 1, 2, 3, 4 \dots 16$$

where, E_{\min} gives the energy of the signal having the least amplitude, f_c as carrier frequency, T_s as symbol period and a_i and b_i represents a pair of independent integers which will be chosen as per the location of a particular signal point.

In the 16-QAM constellation diagram, rectangular pulse shapes are pretended, the signal $T_x(t)$ can be expanded into a pair of basis function represented as [14]

$$\phi_1(t) = \sqrt{\frac{2}{T_s}} \cos(2\pi f_0 t) \quad 0 \leq t \leq T_s. \quad (4)$$

$$\phi_2(t) = \sqrt{\frac{2}{T_s}} \sin(2\pi f_0 t) \quad 0 \leq t \leq T_s. \quad (5)$$

III. URDHVA TIRYAKBHAYAM VEDIC MULTIPLIER

Vedic multiplication is an ancient form of mathematics reconstituted from the old-fashioned Indian scriptures named as Vedas [15]. Vedic mathematics has sixteen mathematical formulas which are named as Sutras. The Vedic sutra provides unique approach of solving the mathematical calculation, such as trigonometry, algebra, arithmetic and calculus into a simpler form [16]. Urdhva Tiryakbhyam (Vertical and Crosswise) sutra is used in the Vedic multipliers to reduce the repetitious multiplication steps and generates parallel partial products. This Vedic sutra is used in the digital multiplication which helps to reduce the hardware complexity and propagation delay in the multiplier circuit. Urdhva Tiryakbhyam algorithm rule is used to generate $n \times n$ bit multiplications. A simple 4-bit digital multiplier architecture based on Urdhva Tiryakbhyam (Vertical and Crosswise) sutra is shown in Figure 2.

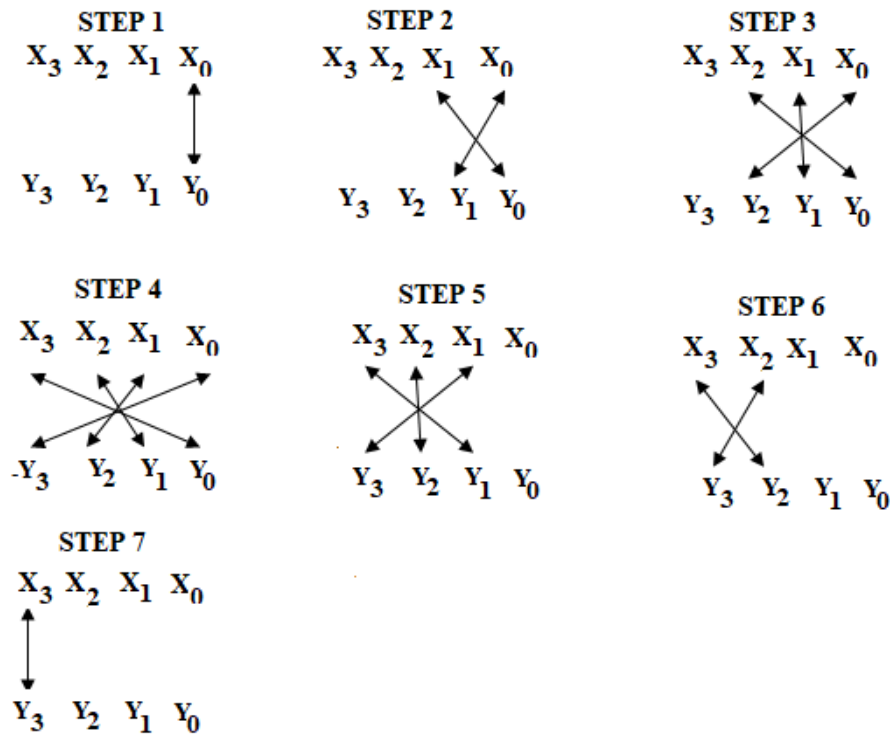

Figure 2 Urdhva Tiryakbhyam multiplication of two 4-bit binary number

Urdhva Tiryakbhyam multiplication rule used for two binary numbers X and Y made by four bits each, i.e., $(X_3 - X_0)$ and $(Y_3 - Y_0)$ [17]. The final output of Urdhva Tiryakbhyam 4 * 4 Vedic multiplier is expressed in the below equations (6) – (12) accordingly to acquire the ultimate product.

$$P_0 = X_0Y_0 \quad (6)$$

$$C_1P_1 = X_1Y_0 + X_0Y_1 \quad (7)$$

$$C_2P_2 = C_1 + X_2Y_0 + X_1Y_1 + X_0Y_2 \quad (8)$$

$$C_3P_3 = C_2 + X_3Y_0 + X_2Y_1 + X_1Y_2 + X_0Y_3 \quad (9)$$

$$C_4P_4 = C_3 + X_3Y_1 + X_2Y_2 + X_1Y_3 \quad (10)$$

$$C_5P_5 = C_4 + X_3Y_2 + X_2Y_3 \quad (11)$$

$$C_6P_6 = C_5 + X_3Y_3 \quad (12)$$

Compressor adders are used to add more than four data bits at a time and achieve less propagation delay over conventional combinational circuits like half adders and full adders [18]. It is used to reduce the gate count and delay while performing addition operation, therefore it is called as compressor. The partial products attained in the Urdhva Tiryakbhyam Vedic multiplier are added using compressor adder. 16-bit Vedic multipliers are used in 16-QAM transceiver design. To add the parallel partial products of 16-bit Vedic multipliers, four compressor adder architectures namely 5-3, 10-4, 15-4, and 20-5 are used. The compressor adders are used to enhance the speed of the multiplication process and reduce the critical delay as compared to existing adder architectures.

A 5-3 compressor adder architecture used in 16-bit Vedic multiplier is shown in Fig.3 [19]. This adder circuit adds five bits $[P_0 - P_4]$ at a time and yields three bit output $[S_0 - S_2]$. It is designed using logic gates, half and full adders.

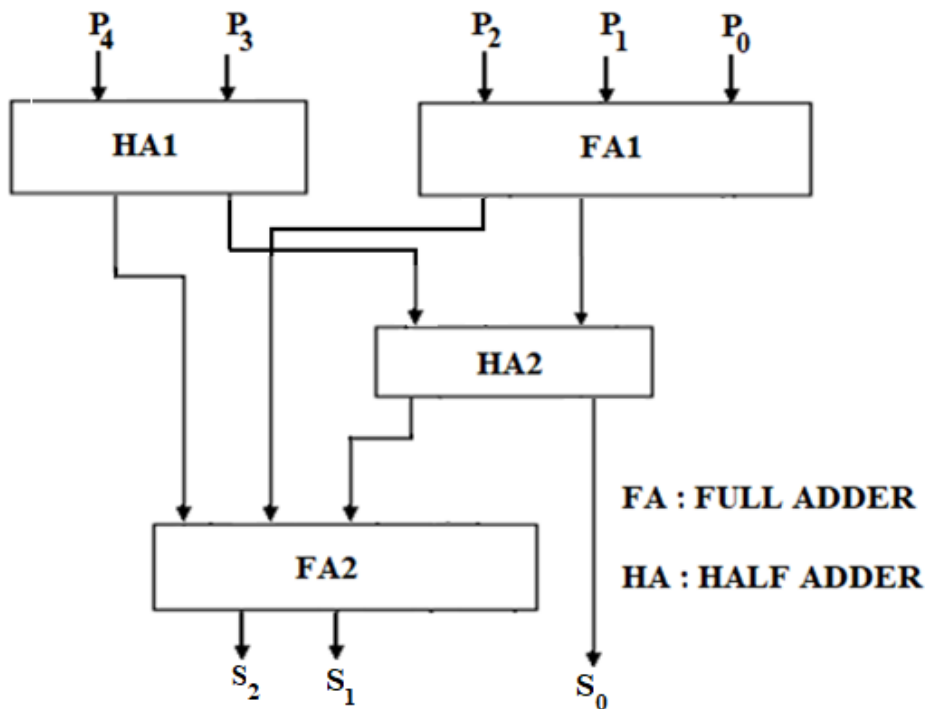

Figure 3. 5-3 compressor adder with half adders and full adders

A 10-4 compressor adder architecture used in 16-bit Vedic multiplier is shown in Fig.4 [19]. This adder circuit adds ten bits [$P_0 - P_9$] at a time using two 5-3 compressor adders and yields four bit output [$S_0 - S_3$]. A 10-4 compressor adder circuit used to reduce delay and enhanced the speed of the multiplier circuit.

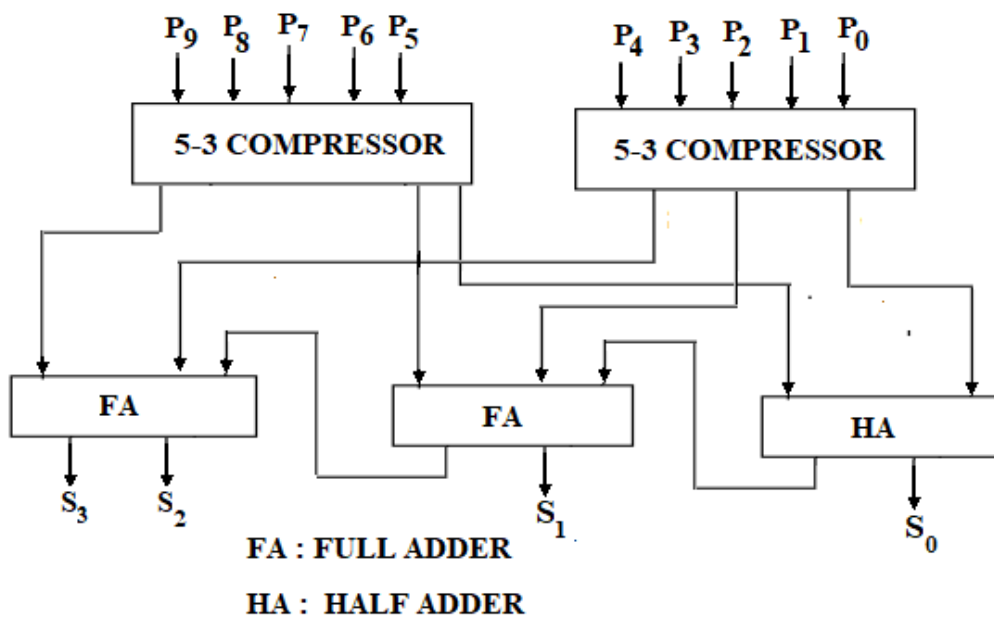

Figure 4. 10-4 compressor adder using 5-3 compressor adders

A 15-4 compressor adder is used to add 15 bits $[P_0 - P_{14}]$ at a time using two 5-3 compressor adder, four bit parallel adder and obtained four bit output $[S_0 - S_3]$. A 20-5 compressor adder architecture used in 16-bit Vedic multiplier which is shown in Figure 5 [19]. This adder circuit adds 20 bits $[P_0 - P_{19}]$ at a time using a 15-4 and 5-3 compressor adder, two half and full adders and obtains five resultant bits $[S_0 - S_4]$.

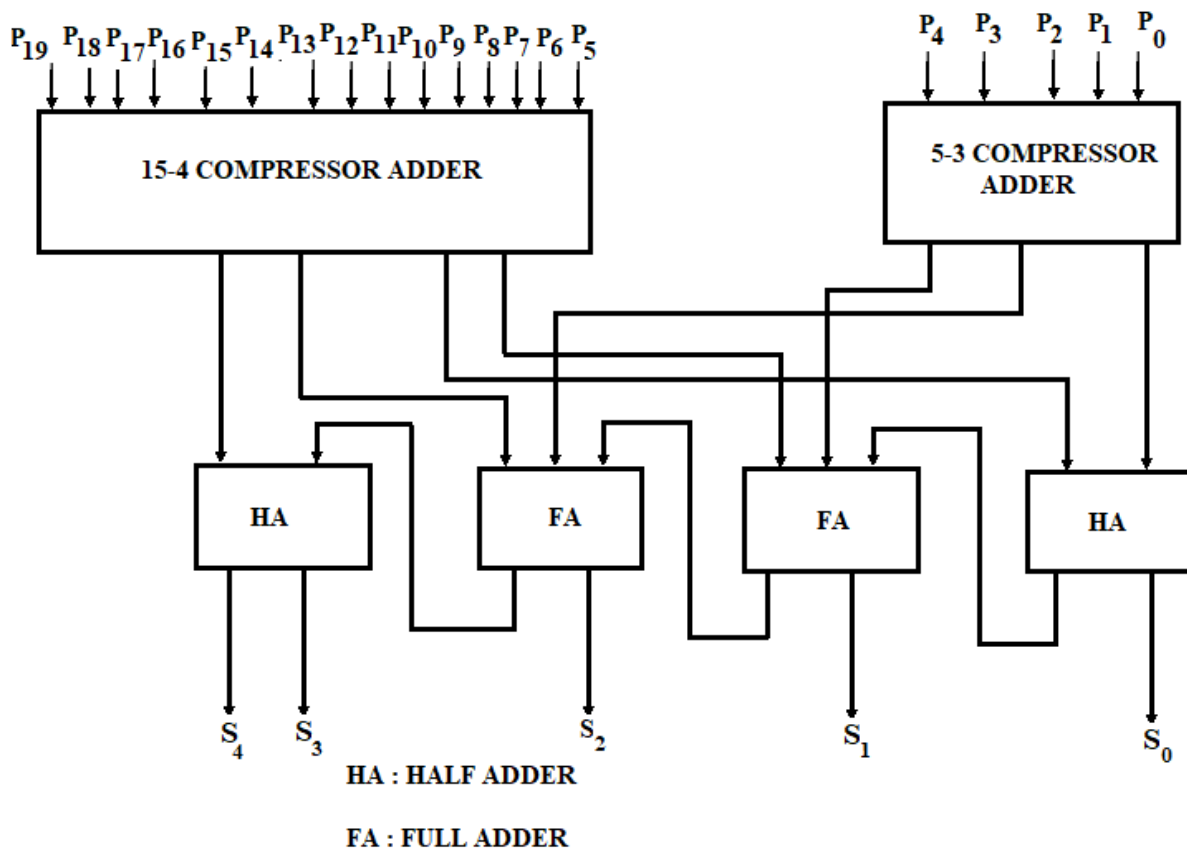

Figure 5 20-5 compressor adder using 15-4 and 5-3 compressor adder

The multiplier structures used in the 16-QAM design increases the latency and processing time. The compressor adder based on Urdhva Tiryakbhyam Vedic multipliers is used in the 16-QAM transceiver design improves speed performance and reduced the carry delay as compared to existing multiplier architectures. The parallel partial products obtained in the 16-bit Urdhva Tiryakbhyam are added using 5-3, 10-4, 15-4, and 20-5 compressor adders.

IV. PROPOSED 16-QAM TRANSCIEVER DESIGN USING VEDIC MULTIPLIER

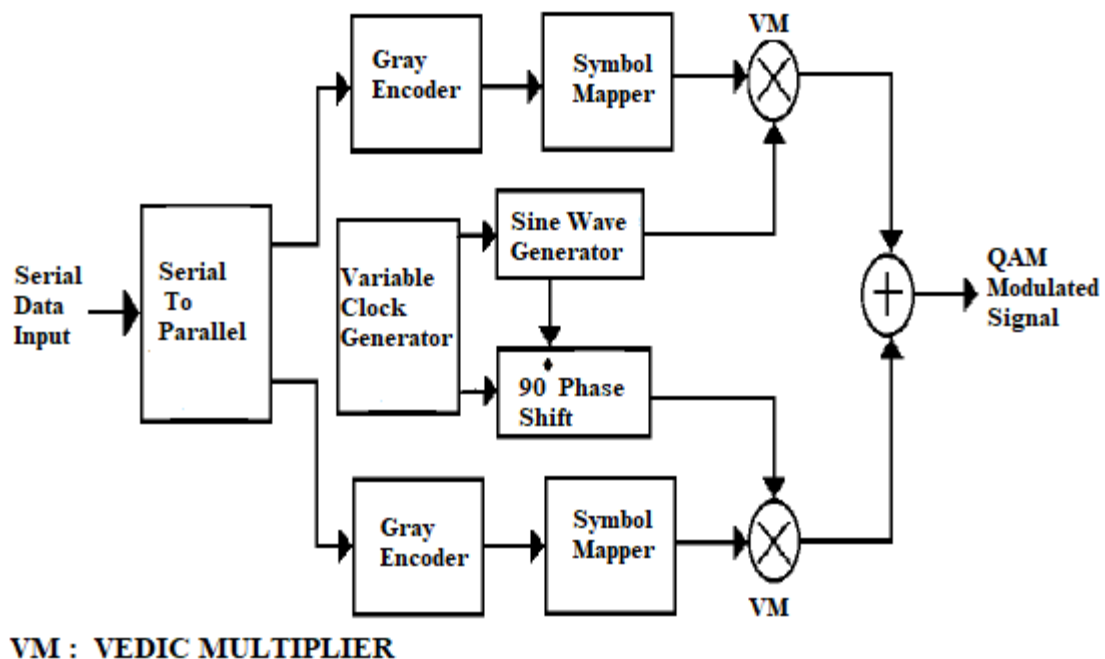
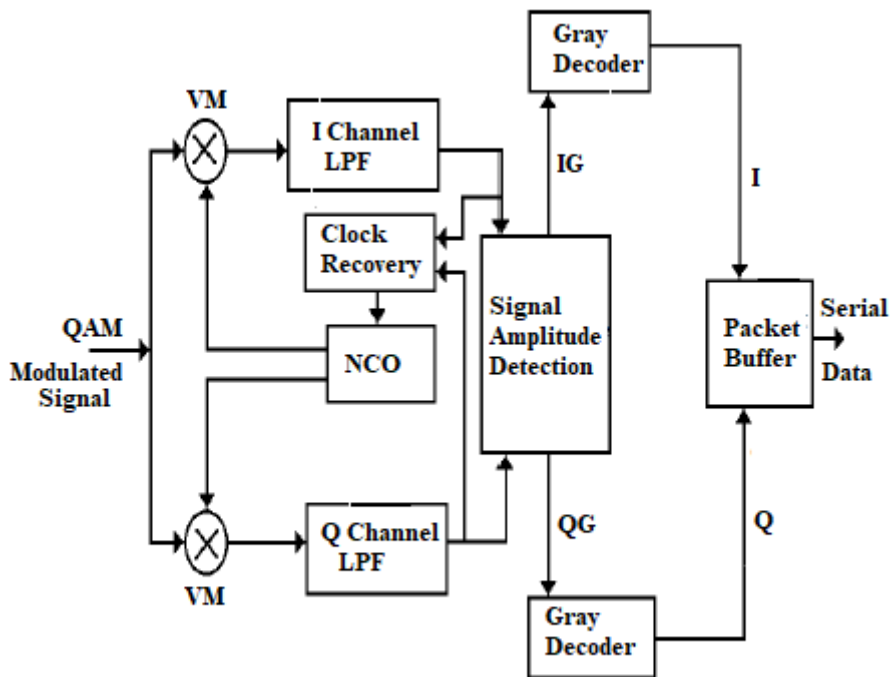

Figure 6 Block diagram of proposed QAM transmitter

The proposed Vedic multiplier based 16-QAM transmitter is shown in Figure 6. The digital data pattern is generated using Pseudo Random Binary Sequence logic and it flows serially as an input to QAM transmitter. Linear feedback shift register (LFSR) is used to generate Pseudo Random Binary Sequence. LFSR is a shift register logic whose input bit is in xored feedback with output bit values. The incoming serial data is encoded by means of four bits and it is divided into two streams as Inphase (I) & Quadrature (Q). The odd values from the encoded bits are taken for I component and even values are taken for Q component. The I and Q bits flows into gray encoder block to reduce the bit errors during data transmission. The symbol mapper is used to combine gray coded bits of I and Q to form symbols. The gray coded bits of I and Q are modulated by variable clock frequencies (150 Hz to 19.2 KHz) with sine and cosine carriers to attain Inphase modulation and Quadrature modulation. Finally, both the modulations are added to form QAM modulated signal. The QAM modulated signal is varied by amplitude and phase.



VM : VEDIC MULTIPLIER

Figure 7 Block diagram of proposed QAM receiver

The block diagram of the Vedic multiplier based QAM receiver design is shown in Figure 7. The QAM modulated signal flows as input to QAM receiver. The sine and cosine carriers are generated using Numerically Controlled Oscillator (NCO). The compressor adder based Urdhva Tiryakbhyam Vedic multiplier used to multiply the QAM modulated signal with carrier signals, to obtain I and Q demodulation signals. The word length of carrier signals and QAM modulated signal has taken as 16-bits. The parallel partial products obtained in the Vedic multiplier are added using four compressor adder namely 5-3, 10-4, 15-4, and 20-5 adder circuits. To eliminate the high frequency components in I and Q demodulated signals, it is transmitted into low pass filter blocks. The filtered I and Q demodulated signal flows into signal amplitude detection block, to group data range and attain the transmitted data. Accordingly, the resultant bits IG & QG from the signal amplitude detection block flows into gray decoder block, to obtain the Pseudo Random Binary Sequence transmitted data.

V. SIMULATION RESULTS AND DISCUSSION

The proposed Vedic multiplier based 16-QAM transceiver is implemented using Spartan 3 XC3S200-5 pq208 FPGA board. The Spartan 3 FPGA device is fabricated on advance 90 nm technology can withstand up to 5 million system gates with the lowest cost and it is used for data communication applications. The specification of 16-QAM transceiver design is listed in Table 1

Table 1 Specifications 16-QAM Transceiver design

Master clock	48 MHz
FPGA	Spartan 3 XC3S200-5 pq208
Bit Pattern	Pseudo Random Binary Sequence
Variable Clock Generator	150 Hz to 19.2 KHz
Modulation Techniques	16QAM
Data rate	12 Mbps
Multiplier	16 Bit Vedic Multiplier
Adder	Compressor Adder

The 16-QAM transceiver design has been developed using Verilog HDL. This has been simulated using Modelsim 6.2c simulator. The Pseudo Random Binary Sequence flows serially as an input to 16-QAM transmitter. The simulation results of the bit pattern followed by gray coded bits of I and Q are shown in Figure 8.

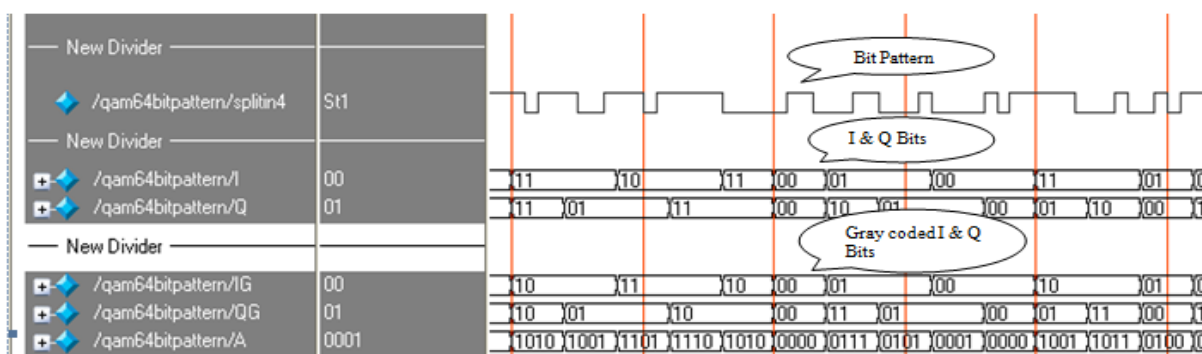

Figure 8 Simulation results of proposed 16-QAM transmitter

The digital bit pattern is encoded using four bits and it is divided into two streams as Inphase (I) & Quadrature (Q). I stream has odd values of the bit pattern and Q stream has even values of the bit pattern. The Inphase & Quadrature data bits are gray coded, to reduce bit errors during data transmission. The simulation results of the variable clock frequencies used in the proposed 16-QAM design is shown in Figure 9.

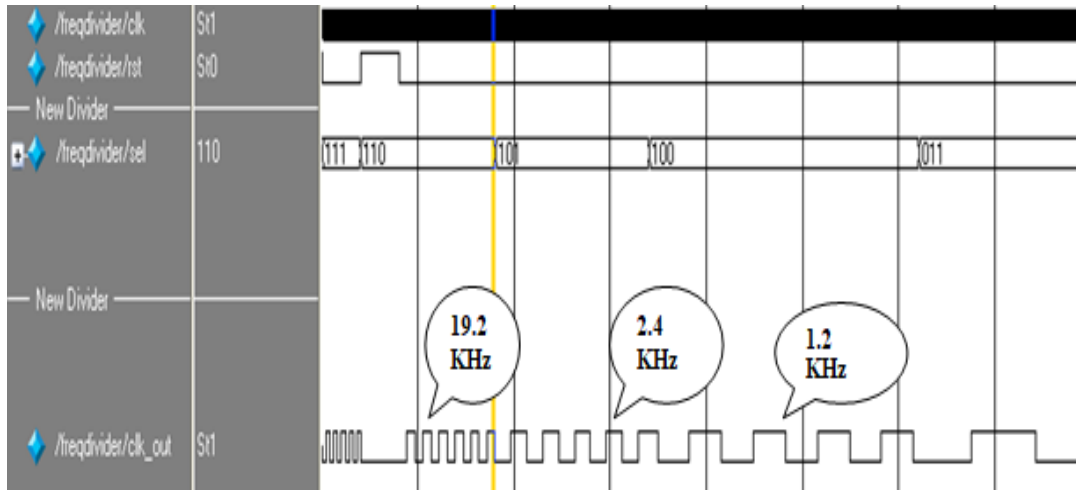

Figure 9. Simulation results of variable clock frequencies in proposed 16-QAM transceiver

The I & Q signals are modulated by sine and cosine carriers with changeable clock frequencies (150 Hz to 19.2 KHz) to achieve Inphase modulation and Quadrature modulation. Finally, the two modulations are added to form QAM signal. The simulation waveform of QAM transmitter is shown in Figure 10

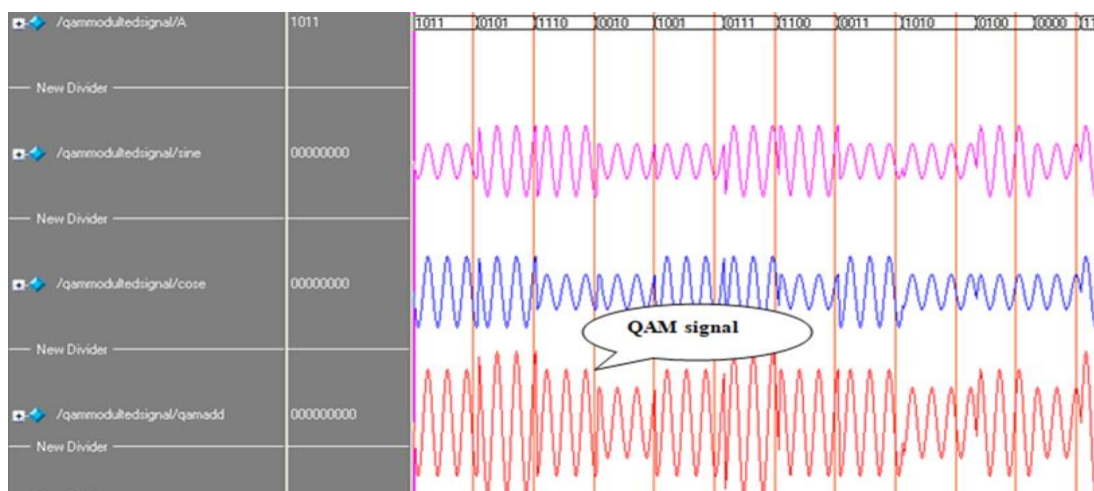

Figure 10 Simulation waveforms of QAM signal

In QAM receiver, the modulated QAM signal is multiplied with carrier signals using Vedic multiplier, to obtain Inphase (I) and Quadrature (Q) demodulation signal. The simulation result of compressor adder based 16-bit Vedic multiplier which is shown in Figure 11.

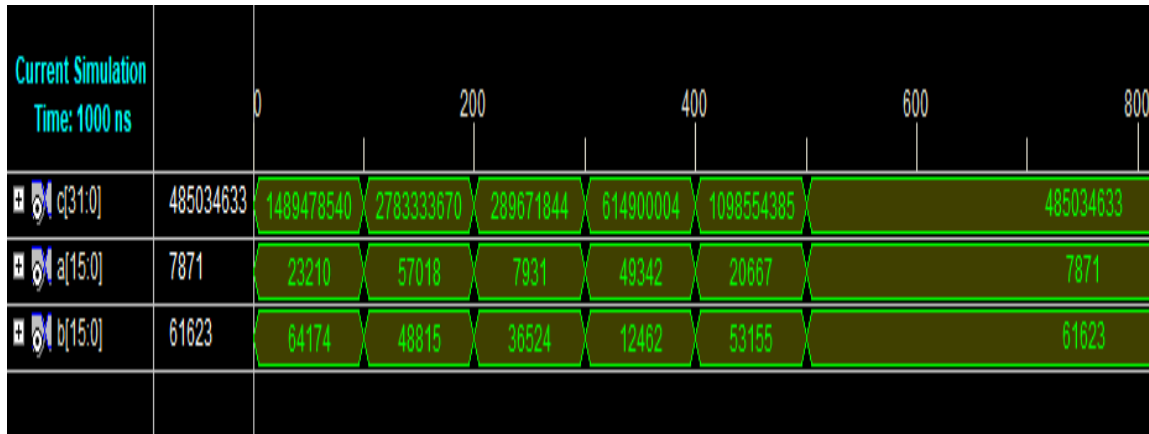

Figure 11 Functional simulation of 16-bit Vedic multiplier

The blocks like low pass filter and signal amplitude detection are used to demodulate the QAM transmitted signal and decoded using gray coder to achieve serial transmitted data. The transmitted and received bit patterns of 16-QAM transceiver are shown in Figure 12.

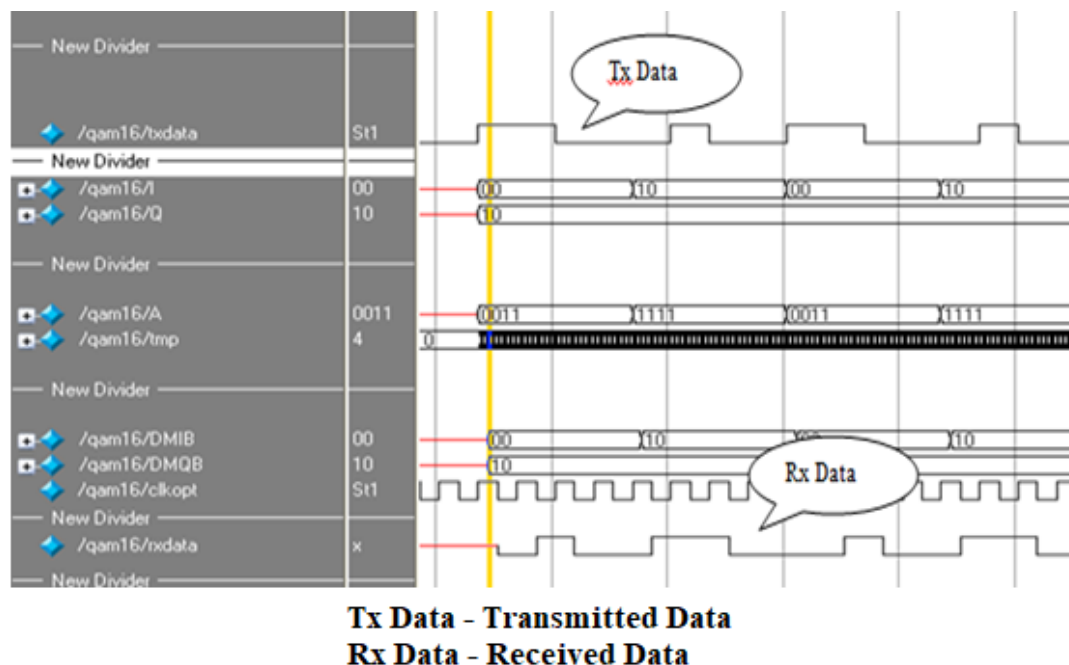

Figure 12 Simulation results of transmitted and received bit patterns

The RTL schematic of the Vedic multiplier based 16-QAM transceiver design is shown in Figure 13. The 16-QAM transceiver design is implemented using Spartan-3 FPGA device occupies 672 slices, 1102 4-input LUTs and 39 mW of power consumption. Table 2 exhibits the comparison results of various 16-QAM designs.

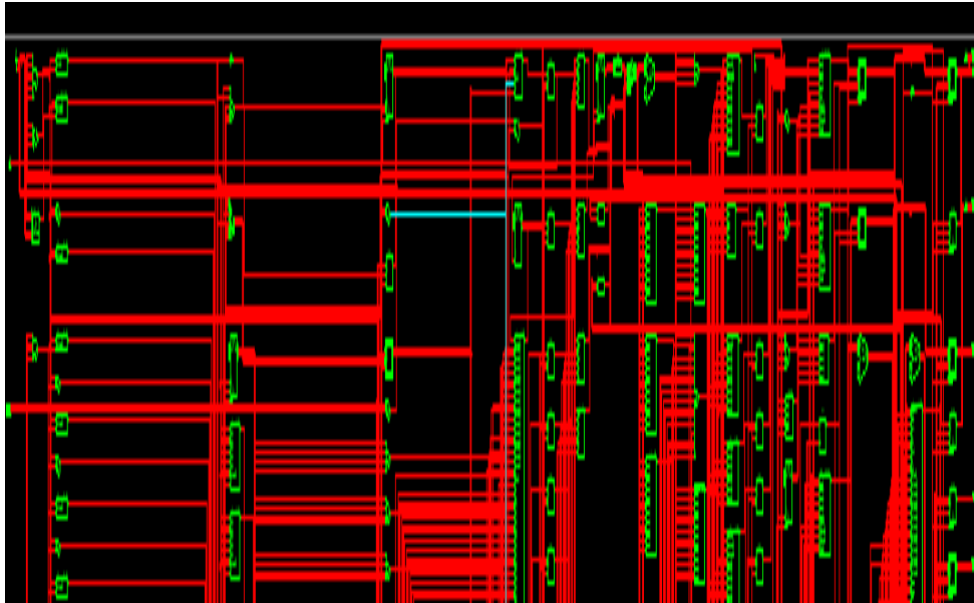

Figure 13 RTL schematic of proposed 16-QAM transceiver

Table 2 Performance comparison of various 16-QAM designs

Parameters	Proposed 16-QAM transceiver	Tarig Hyder Makki <i>et al.</i> 2015.	Satyanarayana <i>et al.</i> 2011
FPGA	Spartan 3	Spartan 3	Spartan 2E
Device	XC3S200 -5 pq 208	XC3S 50 -4 pq 208	XC2S200 -5 pq 208
No. of Slices	672	812	2922
No. of Slices flip flops	384	1238	2252
No. of 4 input LUTs	1102	1154	4674
Gate count	66,232	83,839	151,213
Maximum Frequency	132.31 MHz	85.31 MHz	102.41 MHz

The Vedic multiplier based 16-QAM design reduces 17.2% slices and 4.5% 4-input LUTs compared to the 16-QAM design (Tarig Hyder Makki *et al.* 2015). The same 16-QAM design reduces 77% slices and 76.4% 4-input LUTs compared to the existing 16-QAM design (Satyanarayana *et al.* 2011). The 16-QAM design occupies 66K gates and operates with maximum frequency of 132.31 MHz in Spartan 3 FPGA device. As compared to existing 16-QAM designs, Vedic multiplier based 16-QAM occupies less slices and LUTs in the FPGA device. Hence the proposed 16-QAM provides an area efficient architecture in FPGA

VI. CONCLUSION

In this paper, compressor adder based Vedic multiplier is introduced into 16-QAM transceiver design to obtain area efficient FPGA architecture. The 16-QAM design is implemented using a Spartan-3 XC3S200-5 pq208 FPGA board, which occupies 66K gates and operates with clock frequency of 132.31 MHz. The proposed 16-QAM design attained 17.2% reduction in number of slices and 4.5% reduction in 4-input LUTs. As compared to existing 16-QAM design, the Vedic multiplier based 16-QAM design achieves significant area reduction. 16-QAM is selected digital modulation technique which reduces bit errors during digital data transmission. Hence, the proposed 16-QAM design can be used in OFDM system for high speed wireless applications.

REFERENCES

- [1] Devang K Bhavsar (2014), "Implementation of QAM Modulator on FPGA with ADC/DAC" International Journal for Scientific Research & Development, 2:903-906.
- [2] Anareen Augustine Gomez, Anjana R Menon, Aparna V G, Deepiks C S (2016), "FPGA IMPLEMENTATION OF QAM" 4: 77-79.
- [3] Tarig Hyder Makki, Ali Maysara Mahmoud & Ghassn MT Abdalla (2015), 'Implementation of 16-QAM Transmitter and Receiver on FPGA', Web Applications and Networking (WSWAN), DOI: 10.1109/WSWAN.2015.
- [4] Ravindra H Sharma, Kiritkumar R Bhatt (2015), "A Review on Implementation of QAM on FPGA" International Journal of Innovative Research in Computer and Communication Engineering, 3:1684-1688.
- [5] Satyanarayana, BVV, Pravin, A, Shafivullah Mohd & Kanaka Durga, S (2011), 'Design of Quadrature Amplitude Modulation System for Wireless Applications', International Journal of Electronics and Communication Technology, 2:241-243.

- [6] Dayakara Reddy D, Karunakar Reddy S (2013), 'FPGA Implementation of QAM Transmitter and Receiver', International Journal of Engineering Research and Applications, 3 : 48-51.
- [7] Majid S Naghmash, Mohd Fadzil Ain, Chye Yin Hui (2009), 'FPGA Implementation of Software Defined Radio Model based 16QAM', European Journal of Scientific Research, 35 :301-310.
- [8] Ganesh Kumar G, Charishma V (2012), Design of High Speed Vedic Multiplier using Design of High Speed Vedic Multiplier, International Journal of Scientific and Research Publications 2 : 1 – 5.
- [9] Shital Dhabale, Videsha Menghre, Rohan Lodhi, Trupti Rathod, Pranit Thawkar, Saket Sathwane (2015), Performance analysis of Urdhva and Nikhilam Multiplier, Proceedings of 21st IRF International Conference, ISBN: 978-93-82702-78-8.
- [10] Saha A, Banerjee A, Dandapat P Bhattacharyya (2011), ASIC design of a high speed low power circuit for factorial calculation using ancient Vedic mathematics, Microelectronics journal 42: 1343–1352.
- [11] Prashant .D. Pawale, Venkat N Ghodke (2015) High speed Vedic multiplier design and Implementation, International Journal of applied research 1: 239-244.
- [12] Virendra Magar (2013) Area and speed wise superior Vedic multiplier for FPGA based arithmetic circuits. International Journal of computational engineering research 3: 44-49.
- [13] Payal B. Khobragade, A. M. Shah (2018), "A Review of Reconfigurable Architecture for QAM Modulators", International Research Journal of Engineering and Technology, 1:471-473.
- [14] Raghunandan Swain & Ajit Kumar Panda 2012, 'Design of 16-QAM Transmitter and Receiver: Review of Methods of Implementation in FPGA', International Journal of Engineering and Science, 1 :23-27.
- [15] Jagadish K N, Nagaraj C (2013), High Speed Signed Multiplier For Digital Signal Processing Applications, International journal of Innovative Research and Development 2 : 765 – 778.
- [16] Poornima M, Shivaraj Kumar Patil, Shivukumar, Shridhar K P, Sanjay H (2013), Implementation of Multiplier using Vedic Algorithm, International Journal of Innovative Technology and Exploring Engineering 2:219 – 22.
- [17] K.Naresh, G Sateesh kumar (2014) A Novel Architecture for Radix-4 Pipelined FFT Processor using Vedic Mathematic Algorithm. IOSR Journal of Electronics and Communication Engineering 9: 23 – 31.
- [18] Anusree T U, Bonifus P L, "A Study on Compressor Adders for Fast Multipliers", International Journal of Engineering Research & Technology, 5: 633-635.

[19]Yogita Bansal, Charu Madhu (2016) A novel high-speed approach for 16 X 16 Vedic multiplication with compressor adders. Computers and Electrical Engineering 49: 39-49.